

York University Building Standards

Note to the Designer/Architect/Engineer: These standards are basic minimum criteria to be met in preparing the final project specifications for this section, which is the responsibility of the Designer

1.0 GENERAL	2
1.1 Guideline Principles	2
1.2 Scope of Work	3
1.3 Objectives	3
1.4 Design Criteria	4
1.5 Related York University Standards and Guidelines	4
1.6 References	4
1.7 York University External Sign System	4
1.8 Standard Warranties and Extended Warranties (S.W./E.W.)	5
1.9 Index of Sign Types	7
1.10 Miscellaneous Signs not classified	7
1.11 Messages	8
2.0 PRODUCTS -Exterior Sign Specifications and Requirements	12
2.1 Materials	12
2.2 Sign Pole Requirements	12
2.3 Sign Blade and Sign Panels	13
2.4 Fastenings	13
2.5 Plastics	13
2.6 Flexible Materials	13
2.7 Coatings	13
2.8 Miscellaneous Materials	14
2.9 Illuminated Signs	14
2.10 Colour Palette	14
2.11 Arrows and Symbols	15
2.12 Typography	17
2.13 University Logo	19
3.0 EXECUTION – Fabrication and Installation	21
3.1 General Requirements	21
3.2 Shop Drawings	21
3.3 Exterior Signs Visual Inventory (Appendix 1)	21
3.4 Specifications for Sign Post Footing	21
3.5 Installation and Location	22
Appendices	
Appendix 1 – Exterior Signs Visual Inventory	24
Appendix 2 – Sign Footing Detail	
Appendix 3 – Sign Blade Attachment Detail, Sign Post Cover Detail	

Prepared by: Paul Mayol, Project Manager, Office of the Vice-President Finance and Administration	Reviewed by: Jayson Purdie, A-tec Signs; Steve Dranitsaris, Sr Executive Officer, Office of the Vice-President Finance and Administration	Authorized by: Richard Francki, Assistant Vice-President Campus Services & Business Operations
---	---	--

1.0 General

1.1 Guideline principles:

.1 York University Signage Standards

Following an extensive re-branding strategy, York University unveiled its new positioning statement and logo in 2002. In the spring of 2003, a new signage system was introduced on campus that incorporates the logo and reflects York University's overall brand identity.

The President of York University requested that signage standards be created to establish a distinct and professional graphic image throughout the University. This helps planners, designers and manufacturers of interior and exterior campus signs achieve a controlled and unified system that maintains brand consistency.

The sign system presented in this document is designed to achieve these ends with economy of material and production costs.

This guideline document details the signage standards for exterior signs at York University, including, but not limited to, jurisdictional signs, way finding signs, parking signs and other types of signs. To be effective, the task of a particular sign to identify, direct, inform or control, must be clearly understood and well organized so the correct choices of sign type and message can be made.

Prior to beginning any type of sign work on behalf of York University, please review this manual and familiarize yourself with all relevant details that apply to your application requirements. Henceforth, all York University exterior signage must adhere to the standards outlined in this manual. Standard requirements have been addressed in this manual. However, as the University grows and the program advances, special conditions will arise. These will be handled individually and must be consistent with the standards established in this manual. Should your program have requirements not specified in this manual, a letter of request, outlining requirements must be sent to Campus Planning, Department of Campus Services & Business Operations for review and approval, prior to any work commencing.

1.2 Scope of Work

- .1 This standard identifies minimum requirements for exterior signs. These standards are supplemental to applicable City of Toronto and Ontario Ministry of Transportation requirements which have jurisdiction over street signage related to traffic regulation and safety.
- .2 Scope exclusions
 - .1 The exterior sign standard does not include Temporary Signs, such as:
 - Temporary Construction signs, which are erected from time to time to inform the community about specific projects and identify alternate routes for pedestrian and vehicular traffic;
 - Temporary Event signs, which are put in place by event organizers to direct visitors and other participants to event locations; and
 - University campaigns requiring temporary signage

1.3 Objectives

- .1 The overall objectives of the exterior signage on campus are to serve as and promote the following:
 - Effective integrated wayfinding system
 - Communicator of York identity/brand
 - External landscape of uniformity in sign design and colours
 - Image (strong, coherent, modern)
 - Simplified messaging, made more succinct through a tiered hierarchy
 - Life safety/Emergency Services
 - Transition to an urban environment
- .2 Purpose
 - To visually orient campus community members and visitors to the University
 - To provide a design framework that establishes consistent aesthetic and quality across the campus and from building to building
 - To expedite signage development and installation
 - To acquire exterior signage in a cost effective manner
- .3 This exterior signs standard is also intended to provide a guide in the development of new signs that may not have been developed in the past and therefore may not be covered in this standard. For these situations, the exterior sign standard provides a guide of the necessary development components for new signs.

1.4 Design Criteria

- .1 The exterior sign system is intended to meet the following criteria:

- Provide uniformity of style and brand for exterior signs
- Provide a modular platform for various sign types providing consistency and aid in user recognition
- Signs are categorized by function
- Ability to address ongoing vehicular/pedestrian activity as the campus increases in density, amenities and services
- Nomenclature, typography and colours are standardized
- Colour system complements the brand logo and achieves a distinctive, recognizable “look-feel” to the campus environs
- Materials and finishes adapt to the unique architectural features of the campus and buildings
- Sign design maximizes legibility for all constituents within the University community
- Include 3 guiding principles for maintenance:
 1. Ease of message change
 2. Durability of finishes
 3. Vandalism-proof hardware

1.5 Related York University Standards and Guidelines

- .1 York University Interior Signage Standards Manual, 2004
(Department of Campus Services and Business Operations)
- .2 York University Visual Standards, 2013
(Communications & Public Affairs Division)

1.6 References

- .1 Ontario Building Code
- .2 American Institute of Graphic Arts
- .3 ASTM A 123/A 123M: *Standard Specification for Zinc (Hot-Dip Galvanized) Coatings on Iron and Steel Products*

1.7 York University External Sign System

- .1 The University’s external sign system is generally divided into five functional components, these include:
 - .1 Wayfinding or Directional signs
 - .2 Regulatory signs
 - .3 Jurisdictional signs
 - .4 Donor Recognition/Building Naming
 - .5 Interpretive
 - .6 Temporary
- .2 Within each external sign component there are further functional classifications -- please refer to Table 1 below
- .3 For the purposes of this standard, Temporary signs will not be detailed by this standard and will be addressed in a separate CSBO guideline document

- .4 Key technical requirements:
 - .1 Material finish: needs to be non-glare
 - .2 Colour contrast: Light characters against dark backgrounds or dark characters against light backgrounds
 - .3 Tonal contrast of 70% light reflectance
 - .4 Character (Letter) Spacing:
 - .1 Line spacing: 135% minimum and 170% maximum of the character height
 - .2 Pictograms and numbers: pictograms, characters or symbols must be:
 - .1 international symbols
 - .2 use Arabic numbers
 - .3 have a width-to-height ratio of 3:5 and 1:1
 - .4 have a stroke width-to-height ratio between 1:5 and 1:10 and
 - .5 be upper and lower case/title case
 - .6 shall have a non-glare finish
 - .7 Pictograms shall contrast with their background. Use either a light pictogram on a dark field or a dark pictogram on a light field
 - .8 Exterior signs are not required to have tactile characters or symbols or Braille
- 1.8 Standard Warranties and Extended Warranties
- .1 All work and materials shall be guaranteed for one (1) year to be free from defects and faulty manufacture. Any defective material or work shall be promptly repaired or replaced by the sign installer without additional cost to York University
 - .2 During the first year of sign installation, the sign installer shall fully maintain signs that have been installed, undertaking regular inspection

Table 1: York University Exterior Sign System

WAYFINDING	-	-	Entrance Pylon
			- Vehicular Directional
			- Custom Directional
			- Parking Directional
			- Parking Lot Identification
			- Parking Lot/Garage Zones
			- Pedestrian Directional
			- Building Identification
			- Building Information
REGULATORY	-	-	Traffic
			- Parking
JURISDICTIONAL			
DONOR RECOGNITION/ BUILDING NAMING			Custom (e.g., wall-mounted steel pin-letters, etc.)
INTERPRETIVE			Celebrate and educate community members and visitors about heritage features of each campus (e.g., woodlots, ecological features, historical buildings, etc.).
TEMPORARY	-	-	Construction
			- Vehicular Directional
			- Pedestrian Directional
			- Project Information
			- Events
			- Campaigns

1.9 Index of Sign Types

- W2.1 - Campus Entrance Pylon
- W2.2 - Vehicular Directional
- W2.3 - Parking Directional
- W2.4 - Parking Lot Identification
- W2.5j - Surface Lot Parking – CCTV sign
- W2.6a - Surface Lot Parking - Fire Route
- W2.6b - Surface Lot Parking - Tow Away Zone
- W2.6c - Surface Lot Parking - Do Not Block Pathway
- W2.6d - Surface Lot Parking - Telecom Reserved
- W2.6e - Surface Lot Parking - Office for Persons with Disabilities
- W2.6g - Surface Lot Parking - Medical Only
- W2.6h - Surface Lot Parking - Service Vehicles Only
- W2.6i - Surface Lot Parking - Reserved Day / Night
- W2.6j - Surface Lot Parking – Pay and Display
- W2.6m - Surface Lot Parking – Building Specific Permit Pass Only
- W2.7 - Surface Lot / Parkade Zone ID
- W2.8 - Multi Level Parkade Interior Section (same as W2.7)
- W2.9 - Parkade Rate Board
- W2.10 - Custom Signs primarily for Glendon campus
- W2.11 - Pedestrian Multidirectional Fingerpole
- W2.12 - Map Display
- W2.13 - Building Identification
- W2.14a - No Entry Sign (parkade)
- W2.14b - Entrance Sign (parkade)
- W2.15 - Scrolling Entrance/No Entry Sign, one-sided (parkade)
- W2.16 - Ceiling Hung Backlit Entrance/No Entrance, two-sided (parkade)
- W2.17 * - Building Information
- W2.18 - Flag Mounted Directional
- W2.19 - Custom Pedestrian Directional Information (same size as W2.6 series)
- W2.22 - Jurisdictional
- W2.23 - Bus Waiting Signs – sign type not implemented
- W2.24 - Building Information, Multi-Tenant

** In order not to proliferate the campus with signage, Building Information signs are in limited use – generally to list several key campus destinations or University level research units housed in the building. Building occupants are generally listed on the interior directory board of the building.*

1.10 Miscellaneous Signs not classified

1. Glendon Forest signs: regulatory, interpretive, map of trail system, etc.
2. Building Hours sign
3. Interpretive Signs (e.g. natural/historical campus features)
4. Donor signs (e.g. Lassonde, Kaneff, Schulich, Sherman)
5. Temporary building signs (e.g. YRT, Kinsmen)
6. Secondary blades on Parking Lot Identification (W2.4) and Building Identification (W2.13) signs – see also section 1.11.5

1.11 Messages

.1 **Campus Entrance Pylons (W2.1)**

- Brand Logo
- Campus Name (e.g., Keele Campus)
- Street Name at entrance (e.g., Shoreham Drive)

Campus Entrance Pylons, Glendon Campus

- Brand Logo
- Campus Name (bilingual): Campus Glendon Campus
N.B. French precedes English
- Street Address: 2275 Bayview Avenue

.2 **Vehicular Directional (W2.2), Keele Campus**

- Brand Logo
- Up to 4 street names/messages with directional arrows, normally, ordered in sequence, with most immediate street listed first – n.b., no building names
- For outbound locations, messages can include major arterial roads and highways (with distances)

Vehicular Directional, Glendon Campus

- Brand Logo
- Up to 4 building names/messages with directional arrows, normally ordered with most immediate principal building listed first
- Proper name of building listed in message only (serves both languages) with arrows or universal symbols (i.e. for parking) – no use of the word “building, hall, residence, field house”

.3 **Parking Lot Identification (W2.4) - Keele Campus**

- Brand logo
- Primary: “Reserved Parking” or “Visitor Parking” or both – larger lettering
- Secondary: Name of Parking Lot (along bottom of blade) – smaller lettering

- Tertiary: “Unauthorized vehicles parked in this area will be tagged and/or relocated at owner’s expense” – even smaller lettering

Parking Lot Identification (W2.4) - Glendon Campus

- Brand logo
- Primary 1: “Stationnement réservé” or “Stationnement des visiteurs”
- Primary 2: “Reserved Parking” or “Visitor Parking”
N.B. French precedes English
- Both primary messages are the same size, in larger lettering
- Secondary 1 and 2: Name of Parking Lot (at bottom of blade) – smaller lettering
E.g., Aire de stationnement C
Lot C
N.B. French precedes English

.4 Multi-Directional Pedestrian Fingerpoles (W2.11) – Keele

- Capacity for up to 5 message blades in each of 4 directions
N.B., 4 message blades are normally preferred
- Messages normally ordered with most immediate principal building listed first
- Primary: Building Name – normally, no use of the word “building” (but we do include “Hall”, “Centre”) and no use of the definite article “the” in a building name; for a lengthy name, the first or first two words are the primary message or
a key campus destination sought regularly by large volumes of visitors to the campus – e.g. Admissions, Art Gallery of York University, CLASP
- Secondary: The balance of the Building Name (excluding the word “building”, where applicable),
or
a key destination located within the building

Multi-Directional Pedestrian Fingerpoles (W2.11) – Glendon

- Capacity for up to 5 message blades in each of 4 directions
N.B., 4 message blades are normally preferred
- Messages normally ordered with most immediate principal building listed first
- 2 Primary messages, both are the same size, in larger lettering, one in French and one in English
N.B. French precedes English
- Primary message is the Building Name or a key campus destination sought regularly by large volumes of visitors to the campus
- If either (or both) the French and English version of the primary name exceeds one line, then the font size for both

versions is reduced to accommodate both messages, each on 1 or 2 lines

.5 **Building Identification (W2.13) – Keele Campus**

- Brand Logo
- Primary: Building Name – in larger size lettering – normally, no use of the word “building” (but we do include “Hall”, “Centre”) and no use of the definite article “the” in a building name; for a lengthy name, the message wraps into a 2nd or 3rd line on the sign blade
- Secondary: Campus Street address – in smaller size lettering – along the bottom of the sign blade
N.B., the secondary message appears only on building identification signs located at the principal entrance to the building, facing the street/walkway in the address
- Tertiary: a singular key campus destination located within the building – in same size lettering as Campus Street address
- In some instances, a Building Identification sign may be used to identify the building entrance of a key campus destination, in which case the Primary message is the name of the key destination
- In some instances an unbranded, plain white secondary blade is affixed to the Building Identification sign pole, below the Building Identification blade, to identify one or more key campus destinations or University-level research units housed within the building
N.B., key campus destinations are those sought regularly by large volumes of visitors to the campus

Building Identification (W2.13) – Glendon

- Brand Logo
- 2 Primary Messages: Building Name, in French followed by Building Name in English – normally, no use of the word “building” (but we do include “Pavilon/Hall” “Centre/Centre”); and no use of the definite article “le/la” or “the” in a building name. Both primary messages are the same size, in larger lettering
- For a lengthy name, each message wraps into a 2nd line on the sign blade
- There are no street addresses at the Glendon campus so there are no secondary messages
 - In some instances, a Building Identification sign may be used to identify the building entrance of a key campus destination, in which case the Primary message is the name of the key destination (e.g., Centre de carriers et d’orientation
Career and Counselling Centre)
- In some instances an unbranded, plain white secondary blade is affixed to the Building Identification sign pole, below the

Building Identification blade, to identify one or more key campus destinations or University-level research units housed within the building

N.B., key campus destinations are those sought regularly by large volumes of visitors to the campus

.6 Building Information

- Brand Logo
- Building Name in white letters within red band at top of sign blade (normally, no use of the word “building” (but we do include “Hall”, “Centre”) and no use of the definite article “the” in a building name
- Normally 5 message blades (slats), each containing a unique message (name of the building occupant – normally a key campus destination or University level research unit)
- Messages do not include designation of the unit (such as “department” or “office”, but we do use “Centre”, “Faculty”, “School”)
- Sign can be customized by manufacturer to include additional or fewer message slats

2.0 Exterior Sign Specifications and Requirements:

2.1 Materials

- .1 All materials for exterior signs shall be new and free from defects
- .2 Sign posts, sign blades, sign post base covers and other external sign components shall be constructed of aluminum in order to minimize the likelihood of rusting. Hardware and other components shall be stainless steel, zinc coated steels or galvanized steel
- .3 Thickness, size and type of aluminum shall be specified in the design drawings for each sign
- .4 All seams shall be straight and symmetrical; there shall be no visible welding joints
- .5 Pole material shall be Aluminum tube
- .6 Hardware material: anchor bolts shall be zinc plated; fasteners shall be stainless steel
- .7 Sign Poles material, fabrication, wind load, installation shall be reviewed for their intended and approved use by a structural engineer licensed in Ontario
- .8 Reviewing and authorizing engineer's stamp shall be provided on each shop drawing

2.2 Sign Pole Requirements

- .1 Sign pole dimensions:
 1. W2.1 – Diameter: 14.13 cm (5.562") Height: 246.38cm (97")
 2. W2.2 – Diameter: 8.89cm (3.5") Height: 181.61cm (71.5")
 3. W2.4 – Diameter: 8.89cm (3.5") Height: 298.1325cm (117.375")
 4. W2.6 – Diameter: 6.03cm (2.375") Height: 142.6cm (56.125")
 5. W2.9 – Diameter: 8.89cm (3.5") Height: 200.98cm (79.125")
 6. W2.11 – Diameter: 8.89cm (3.5") Height: 338.455cm(133.25")
 7. W2.12 – Diameter: 8.89cm (3.5") Height: 200.66cm (79")
 8. W2.13 – Diameter – 8.89cm (3.5") Height – 298.1325cm (117.375")
 9. W2.17 – Diameter: 8.89cm (3.5") Height: 196.85cm (77.5")
 10. W2.18 – Diameter: 8.89cm (3.5") Height: 215.9cm (85")
 11. W2.22 – Diameter: 8.89cm (3.5") Height: 235.2675cm (92.625")
- .2 Pole colour: Metal poles are painted gray in automotive spray booth, colour code Tiger Drylac 59/93370
- .3 Pole base treatment:
 - .1 Base Covers are painted in Spray Booth to match Tiger Drylac 49/92900
 - .2 Base Plates dimensions: 1.905cm (.75") T

2.3 Sign Blade and sign panels

- .1 Sign blades materials used: Aluminum
- .2 Standard dimensions of blades and panels by sign type:
 1. W2.2 – 17.78cm (7”) H x 152.4cm (60”) W
 2. W2.3 – 64.77cm (25.5”) H x 50.8cm (20”) W
 3. W2.4 – 64.77cm (25.5”) H x 97.79cm (38.5”) W
 4. W2.6 – 30.48cm (12”) H x 30.48cm (12”) W
 5. W2.7 – 101.6cm (40”) H x 50.8cm (20”) W
 6. W2.11 – 17.145cm (6.75”) H x 97.155cm (38.25”) W
 7. W2.12 – Enclosure unit is 66.04cm (26”) W;
 - Map Insert dimensions: 96.52cm (38”) H x 60.96cm (24”) W
 8. W2.13 – 64.77cm (25.5”) H x 97.79cm (38.5”) W
 9. W2.17 – 71.12cm (28”) H x 97.79cm (38.5”) W
 10. W2.18 – 132.08cm (52”) H x 91.44cm (36”) W
 11. W2.22 – 30.48cm (12”) H x 182.88cm (72”) W
 12. W2.24 – 121.92cm (48”) W x variable height size, depending on number of blades
- .3 Sign blades and panels are affixed to poles and sign frames using .525mm (0.375”) T Cast Aluminum Brackets (High Strength Low Alloy)
- .4 Secondary blades are permissible to be installed on Building Identification and Parking Lot Identification signs, below the primary sign blade

2.4 Fastenings

- .1 All screws, nuts, bolts, washers and other fastening devices shall be aluminum, stainless steel, or zinc-plated (galvanized) non-corrosive material as per ASTM A123
- .2 All anchorage and fastenings of miscellaneous metal items shall be structurally adequate and finished to match surface

2.5 Plastics

- .1 Clear Lexan plastic is used for campus map sign, 4.7625mm (0.1875”) gauge
- .2 3M Opaque Black Vinyl #7725-12 is used for letters, numbers, and pictographs

2.6 Flexible Materials

- .1 A closed cell neoprene measuring 3.175mm (0.125”) thick is used for gaskets between sign poles and brackets

2.7 Coatings

- .1 All aluminum, metal and fasteners shall be finish coated with an appropriate primer and automotive grade colour coat with corrosion inhibitors guaranteed for four (4) years against fading, chipping, cracking, peeling, and discoloration. Colour as specified in sign standard and specific sign type drawings.
- .2 All flexible face coatings shall be guaranteed for eight (8) years against fading, discoloration and mildew
- .3 All holes, penetrations, and cut edges of pre-finished metals must be free of burrs, primed and painted to maintain a corrosion-proof finish

2.8 Miscellaneous Materials

- .1 Any metal hardware used for the construction of signs, posts, or associated components not previously covered shall be of stainless steel, aluminum, or steel with galvanized coating as per ASTM A123
- .2 pole brackets: cast aluminum
- .3 pole caps: aluminum
- .4 pole base covers: aluminum
- .5 "Tampruf" nuts - Low carb steel factory Cad plated with "Tampruf" machine screw fasteners (with countersunk head) shall be used for sign poles to securely affix individual sign blades to sign poles

2.9 Illuminated Signs

- .1 With the exception of the Campus Entrance Pylon signs (W2.2), illuminated signs are generally not utilized on campus
- .2 Campus Entrance Pylon signs are illuminated using Light Emitting Diodes (LED) technology
- .3 Where sign illumination is deemed necessary - illumination for external signs must take into consideration the need to minimize light pollution (up lighting)

2.10 Colour Palette

- .1 The following material colours shall be used for all York University exterior signs. Deviation from this colour palette must be authorized by York University Signage Committee and the Committee of Master Planning and Facilities.
 1. Background: white, red, black (or grey)
 2. Text: black, red, white
 3. Reveal/Stripe: red
 4. Parking Lot/Garage Zone signs: blue, green, orange, red stripes/bands
 - .1 Red: CMYK code:
 - .1 Paint
 - .2 Silkscreen
 - .3 Vinyl: 3M VT9829 Red Vinyl

- .4 Anodized aluminum
- .2 Black: CMYK code:
 - .1 Paint
 - .2 Silkscreen
 - .3 Vinyl: 3M 7725-12 Black Vinyl
 - .4 Anodized aluminum
- .3 White: CMYK code:
 - .1 Paint
 - .2 Silkscreen
 - .3 Vinyl: 3M 3630-20 White Vinyl
 - .4 Anodized aluminum
- .4 Grey: CMYK code:
 - .1 Paint
 - .2 Silkscreen
 - .3 Vinyl: No Grey Vinyl on Exterior Signs
 - .4 Anodized aluminum
- .5 Blue: CMYK code for both background blue and foreground blue
 - .1 Paint
 - .2 Silkscreen
 - .3 Vinyl: No Blue Vinyl on Exterior Signs
 - .4 Anodized aluminum
- .6 Green: CMYK code:
 - .1 Paint
 - .2 Silkscreen
 - .3 Vinyl: No Green Vinyl on Exterior Signs
 - .4 Anodized aluminum
- .7 Orange: CMYK code:
 - .1 Paint
 - .2 Silkscreen
 - .3 Vinyl: No Orange Vinyl on Exterior Signs
 - .4 Anodized aluminum

2.11 Arrows and Symbols (pictograms)

.1 Arrows

- .1 A single arrow is used throughout the exterior signage program to provide directional assistance
- .2 Standard arrows are rounded tip
- .3 The arrow centre line matches the horizontal centre of the type adjacent to it (as measured from the top edge of a capital letter to the baseline of the type (or the centre of the York logo below it))

- .4 The position of the arrow on the sign varies depending on where the sign is positioned in relation to the destination
- .5 Arrow sample and spacing attached below:

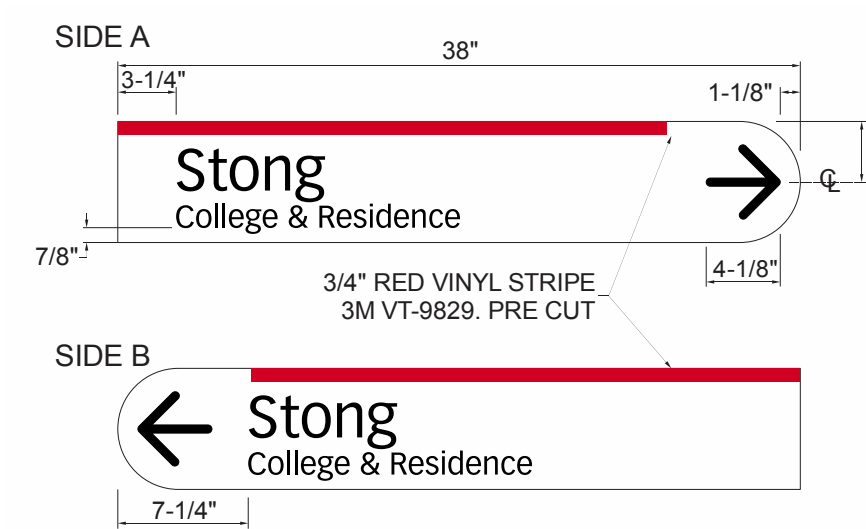

- .6 Pictograms
 - .1 Pictograms are used in exterior signs to communicate simple, concise messages. The pictograms deployed are based on standards endorsed by the American Institute of Graphic Arts



No Entry:

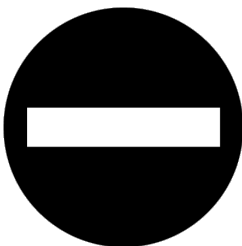

Bus:

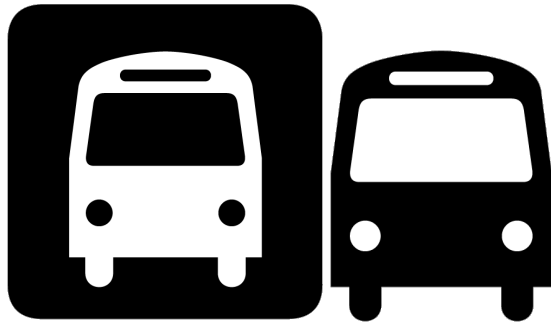

Light on dark background und
Dark on light background und

CCTV camera:



KEELE



GLENDON

24H CCTV

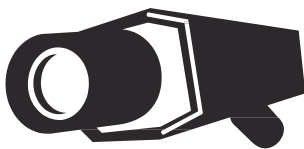

text on CCTV pictogram is Univers 55 Bold, Size 50 pt track 15, colour black alignment left to right with 1 3/8" gutter

2.12 Typography

- .1 For external signs Vectora LT Light Bold and Vectora LT Romer Regular have been used as the Type Style (font) see samples below:

^A A	^B B	^C C	^D D	^E E	^F F	^G G
^H H	^I I	^J J	^K K	^L L	^M M	^N N
^O O	^P P	^Q Q	^R R	^S S	^T T	^U U
^V V	^W W	^X X	^Y Y	^Z Z		

^a a	^b b	^c c	^d d	^e e	^f f	^g g
^h h	ⁱ i	^j j	^k k	^l l	^m m	ⁿ n
^o o	^p p	^q q	^r r	^s s	^t t	^u u
^v v	^w w	^x x	^y y	^z z		

⁰ 0	¹ 1	² 2	³ 3	⁴ 4	⁵ 5	⁶ 6
⁷ 7	⁸ 8	⁹ 9	[!] !	[@] @	[#] #	^{\$} \$
[%] %	[^] ^	^{&} &	[*] *	⁽ (⁾)	[{] {
[}] }	[[] [[]]]	[:] :	[;] ;	[?] ?	^{<} <
^{>} >	⁻ -	⁺ +	⁼ =			

- .2 Letter Spacing:
.1 Spacing between letters should match the shop or technical drawings specified

- .3 Line Spacing:
 - .1 Line spacing sample:

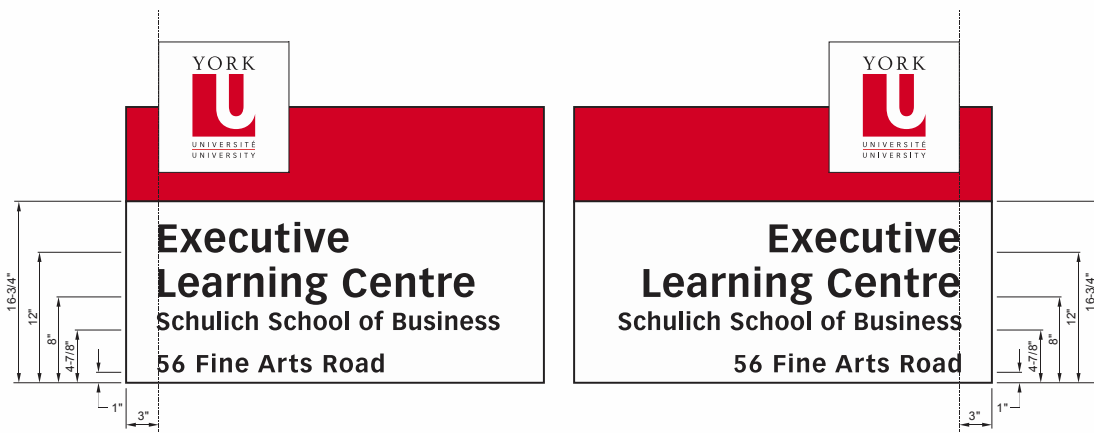

- .4 Layout / Paragraph Style: Flush left
- .5 Letter Height: Refer to individual sign type drawing specifications for designated character heights
- .6 Use of upper and lower case letters:
- .7 Use of a combination of upper and lower case letters is acceptable, as in normal sentence construction
- .8 With the exception of "YORK UNIVERSITY" upper case lettering is not normally used for exterior signs

2.13 University Logo

- .1 Exterior signs produced for the University generally incorporate the official York University logo. The logo is used to identify and brand the University, its buildings and property in all forms of media and graphic applications:
<http://toolbox.info.yorku.ca/>

Exceptions: W2.3 Parking Directional
W2.7 Parking Lot/Garage Zones
W2.11 Pedestrian Directional

- .2 Many exterior signs incorporate the York University official logo. The university's logo incorporates three colours. There are several iterations of the official logo, these official versions of the logo can be referenced in the Visual Standards guide on the York University Communications & Public Affairs web site:

http://toolbox.info.yorku.ca/files/2013/02/YU_VI_Standards_Jan2013.pdf



3.0 EXECUTION - Fabrication and Installation

3.1 General Requirements

- .1 All exterior signs, poles, foundations, anchoring and other elements shall be described in detail in the individual shop drawings or specifications for each individual sign type
- .2 Fabrication of signs and installation shall be undertaken by qualified professionals in accordance with information provided by the specific shop drawings
- .3 Exterior signs shall be fabricated and erected square, plumb, straight and true. Cut-out letters, numbers, arrows, images such as logos or symbols shall be cut to continuous, sharp even line of profile as indicated on shop drawings
- .4 Installers shall provide all supporting and anchoring means as required for proper installation

3.2 Shop Drawings

- .1 Shop drawings for exterior signs shall denote sign type, sign location anchoring method and any other relevant information
- .2 Shop drawings shall be submitted as a PDF file for review and approval to the York University project representative

3.3 Exterior Signs (visual inventory)

- .1 See Appendix 1

3.4 Specifications for Sign Post footing:

- .1 Item E. 3 ½" Ø x 0.188" pole with powder coat finish Tiger Drylac 49/90380 Standard Silver
- .2 Item F. Cast aluminum anchor bolts / base plate decorative cap with powder coat finish Tiger Drylac 49/92900 Silver Gloss Once Coat (see detail)
- .3 Item G. ½" x 12" x 12" base plate
- .4 Item H. ½" x 3'6" anchor bolts @ 6" centres
- .5 Item I. 12" Ø x 4' - 0" concrete base
- .6 Item J. 1" x 1" angle clips (2 off) embedded in concrete for attachment of cover
- .7 Item K. "Tampruf" nuts - Low carb steel Factory Cad Plated with "Tamruf" Machine screw fasteners (with countersunk head)
- .8 Aluminum sign components in contact with ferrous metals shall be separated with a sheet of neoprene
- .9 All accessories, anchorage, mounting devices and spacers shall be guaranteed non-staining to adjacent sign components such as sign blades and sign posts for a period of five years from sign installation (final acceptance). Ferrous metals must be sleeved with a non-ferrous metal cover matching adjacent finishes.

3.5 Installation and Location

Location Criteria:

In locating sign installations, consideration shall be given to:

- .1 Visibility to drivers/pedestrians
- .2 Grounds maintenance requirements, including width and height clearance for snow plowing machinery
- .3 Trees, bushes and other landscaping that impede (or will impede) sign visibility
- .4 Potential damage and ability to restore grounds, walkways and interlock in area of sign installation
- .5 Location of underground utility and service lines, tunnels and other structures
- .6 Obstruction of walkways, roadways, entrances, fire exits or other means of egress, openings for ventilating or lighting, etc.
- .7 Sign blades shall normally be at 90% (perpendicular) to vehicular/pedestrian approach
- .8 Consistency with placements of adjacent sign types, as other considerations permit
- .9 Physical alignment of poles and sign blades with architectural features of buildings

Installation:

- .10 All signs shall be in place as indicated on the drawings or directed by York University project representative.
- .11 Signs shall be secured as per approved shop drawings and of sizes required to assure rigid attachment.
- .12 Survey of ground conditions related to soil content, density and compaction prior to sign post base installation is the responsibility of the sign installer
- .13 Survey of underground utilities prior to digging for sign posts base installation is the responsibility of the sign installer
- .14 Removal and or replacement of asphalt, soil and grass, paving stones, concrete, existing footings and poles are the responsibility of the sign installer unless otherwise specified on drawings

Clean Up

- .15 During the process of sign installation, the work premises shall be kept reasonably free of debris, and waste materials resulting from the work under this section. Upon completion and before final acceptance of work, all debris, rubbish, leftover materials, tools and equipment shall be removed from the site
- .16 Final cleaning of all surfaces shall be carefully undertaken in accordance with the sign manufacturer's instructions

Appendix 1 - Exterior Signs Visual Inventory

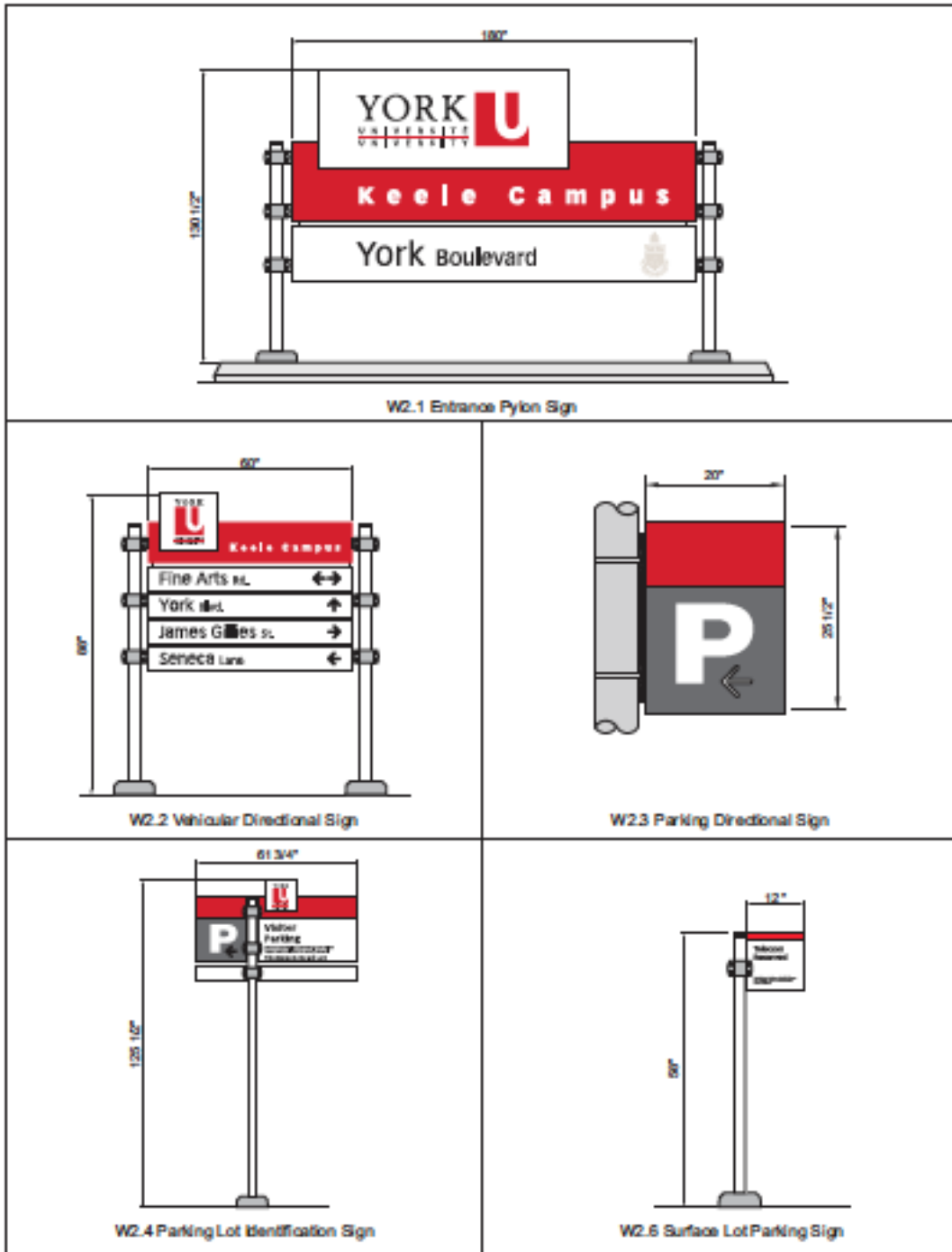

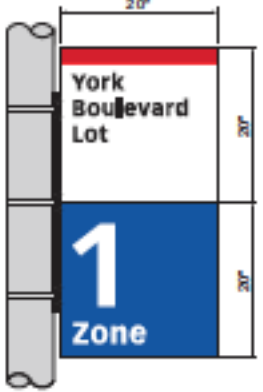
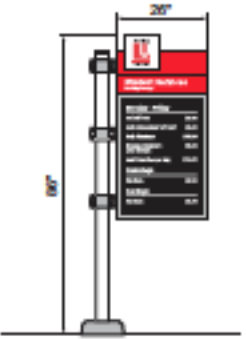
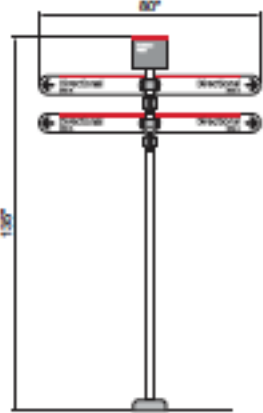
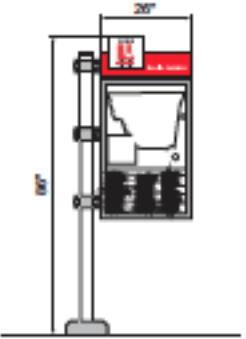
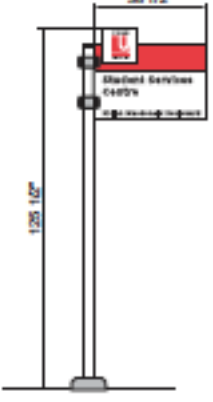
 <p>W2.7 Surface Lot Parkade Zone I.D. Sign</p>	 <p>W2.9 Parkade Rate Board</p>
 <p>W2.11 Pedestrian Multi-Directional Finger Pde Sign</p>	 <p>W2.12 Map Sign</p>
 <p>W2.13 Building ID Sign</p>	

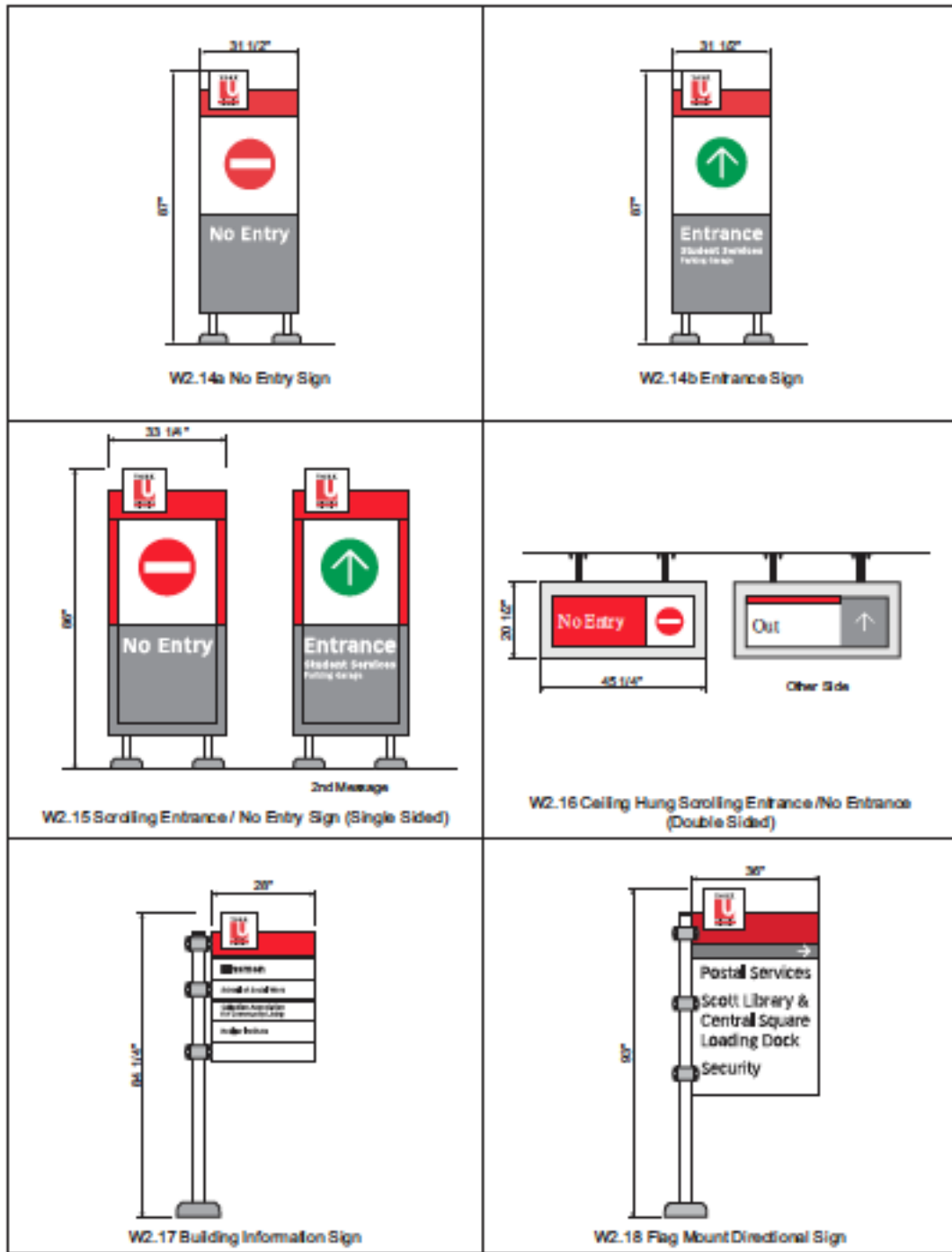

<p style="text-align: center;">W2.22 Jurisdictional Sign</p>	<p style="text-align: center;">W2.23 Bus Waiting Signs</p>
<p style="text-align: center;">W2.22 Jurisdictional Sign - Additional Panel (April 07 2009)</p>	<p style="text-align: center;">W2.24 Building Information - Multi Tenant Sign</p>

Sign Code: W2.13-90 Building ID Sign

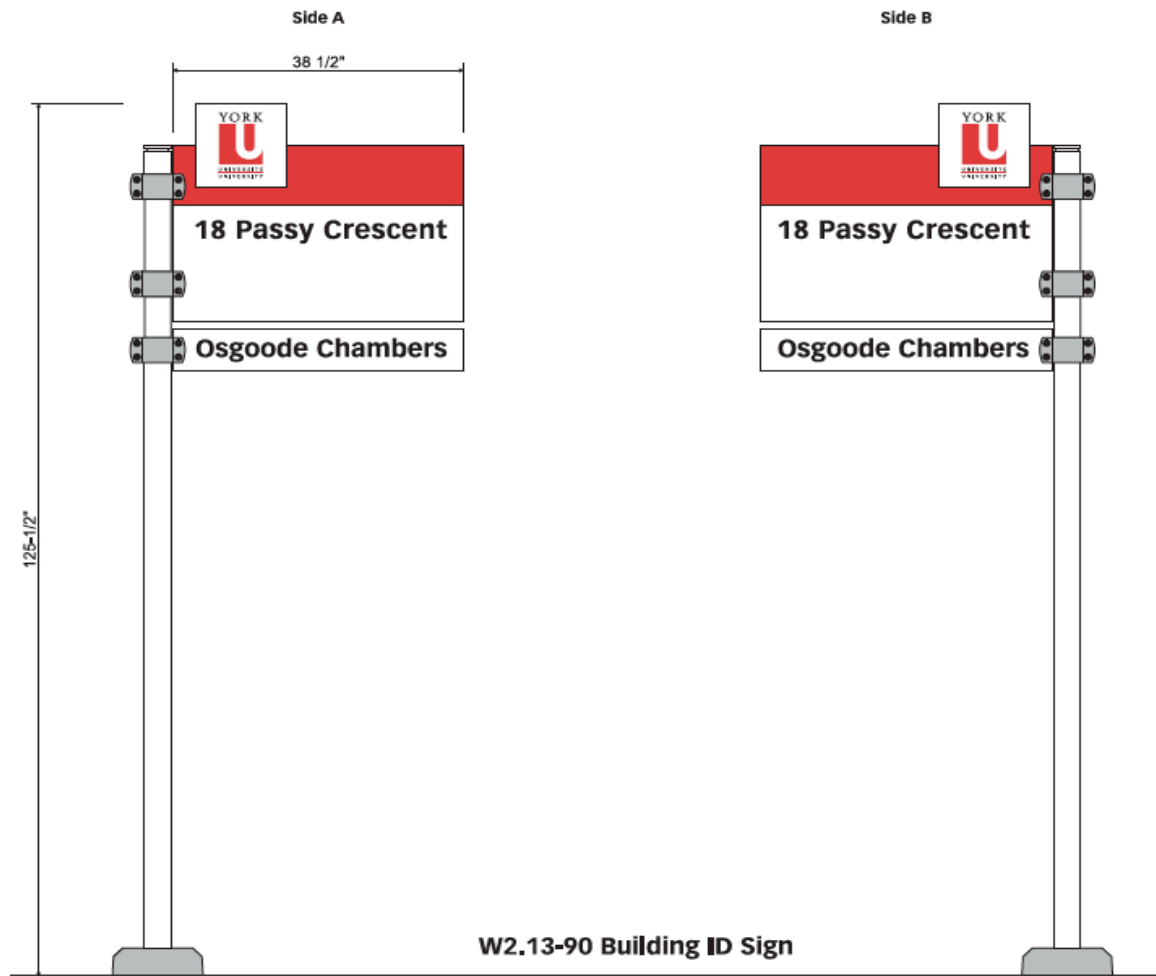

Sign Code: W2.25.03 Building Information Sign

This is a variation of Sign W2.17, but with additional message panels added.

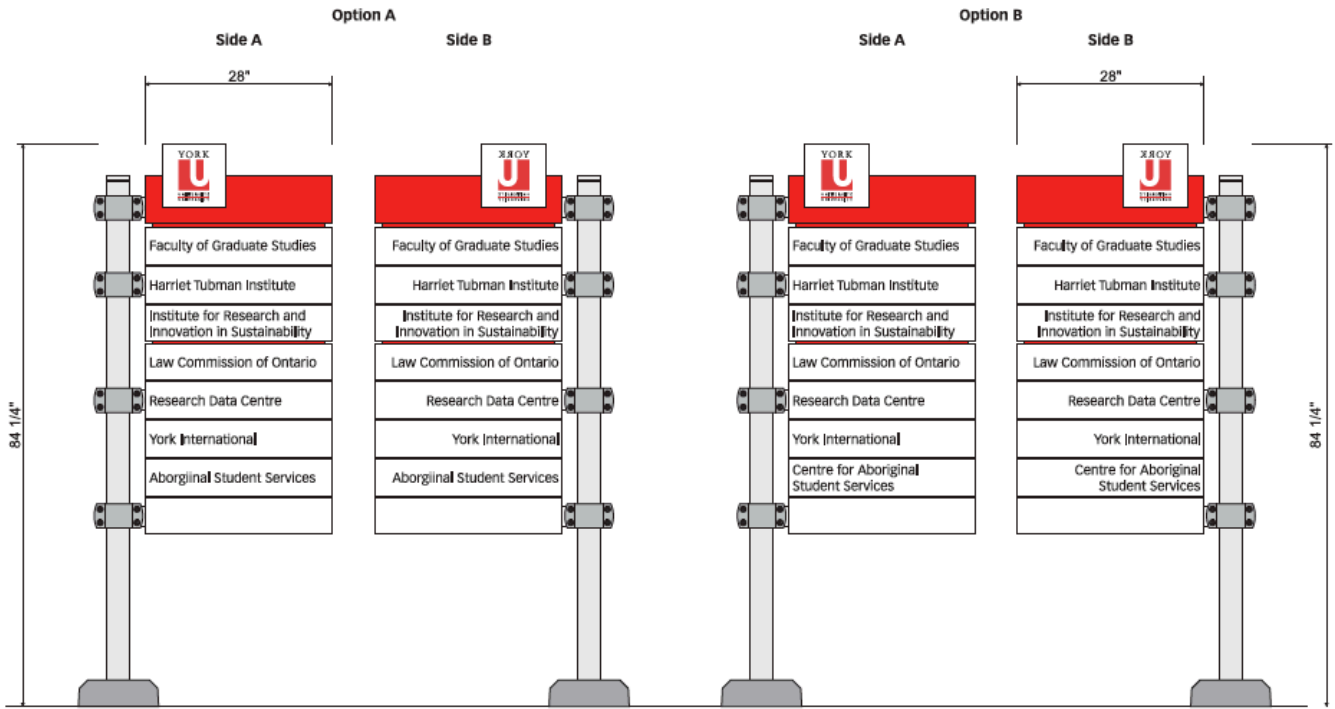

W2.25.03 Building Info Sign

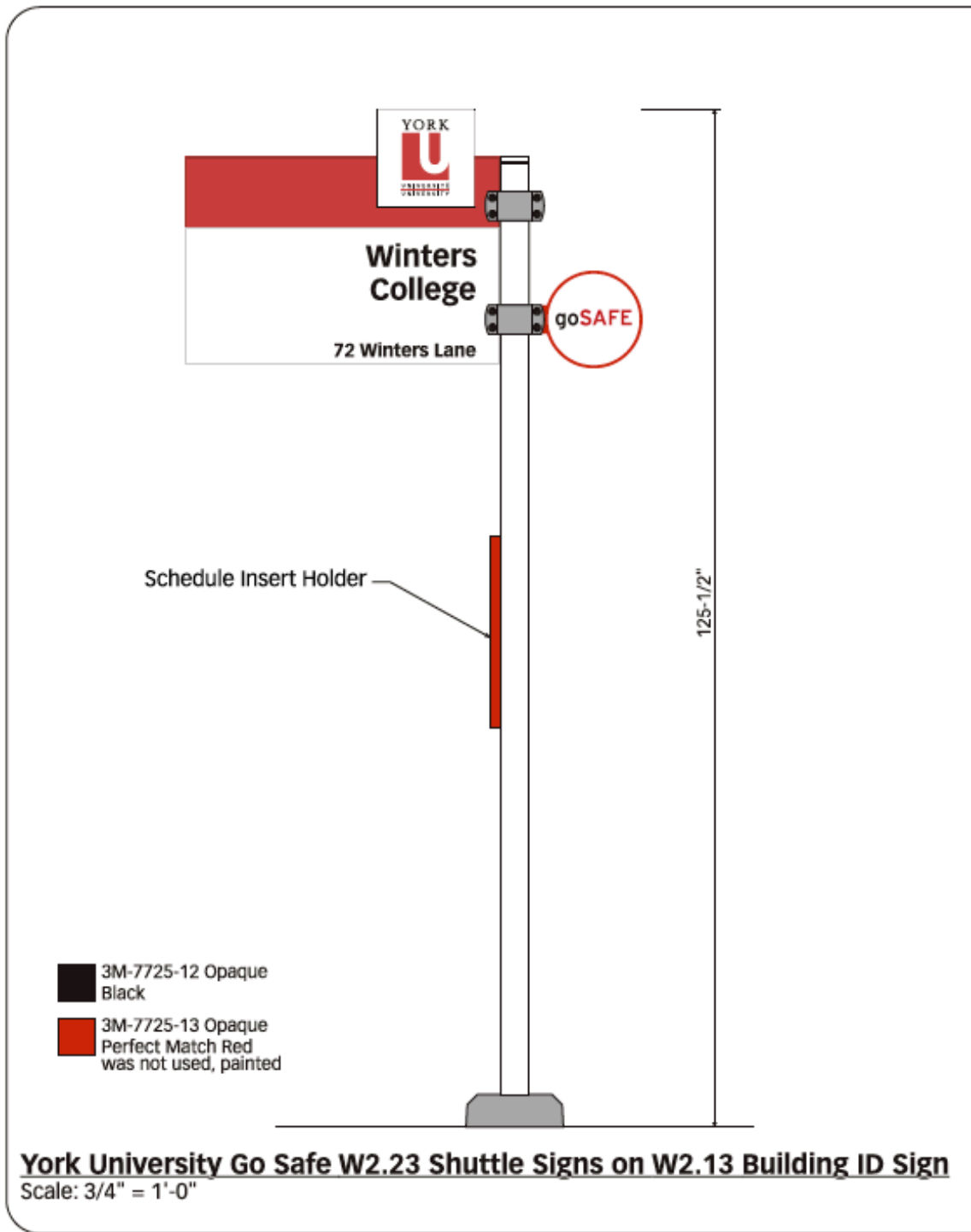

Appendix 2: Sign Footing Detail

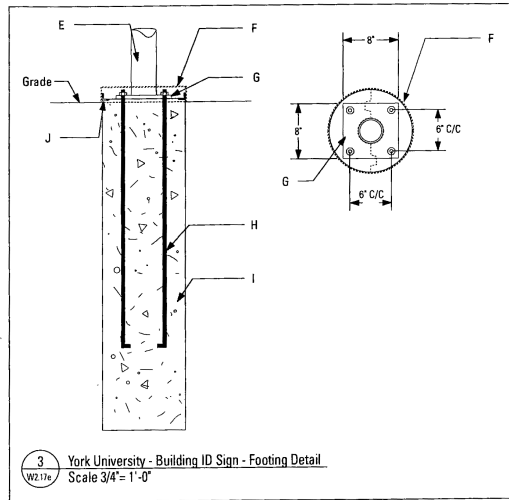

**Appendix 3 Sign blade attachment detail (see detail below)
Sign post cover detail (see detail below)**

